

DOMES PRESSURE REGULATOR 737 LE-HD



Powerful and service reduced Dome Pressure Regulator applicable for mounting in pipe-works.

Benefits

- process reliability by high pressure stability in case of withdrawal fluctuations
- applicable for almost all gases
- accurate dynamic regulation
- high flow rate
- available in brass or stainless steel (ES)
- integrated pilot pressure and manometer connections
- remote control by extern pilot pressure regulator or proportional valve
- several gas supply can be central regulated to the same working pressure
- **Balanced Seat Design (BSD)** for better control precision

Options

- mounted pilot pressure regulator
- inlet- and outlet pressure manometer with individual scale
- inlet- and outlet connections (soldering-, welding- or clamp fittings)
- complete mounted with functional- and leak test

Operation / Usage

Dome pressure regulator are especially suitable for process supply in pipe-works and system engineering. Independent of withdrawal fluctuations the stability working pressure guarantees a constant gas concentration and quality of the down stream processes. Additionally the use in case of high flow rates at low pressure drops is recommended.

Function

The dome pressure regulator is used in combination with pilot pressure regulator (or proportional valve) for adjusting the required working pressure (outlet pressure).

It's possible to use the regulated gas (own medium) or foreign gas as supply of pilot pressure regulator by option.

Maintenance

Annual testing of body leak tightness is recommended. Replace wearing parts of at least 1-3 years. Premounted Maintenance-Kit on request.

Approvals

Company certified according to ISO 9001, ISO 22000 and PED 97/23/EC Module H

Other models, options and accessories available on request.

For more pressure regulator visit www.wittgas.com

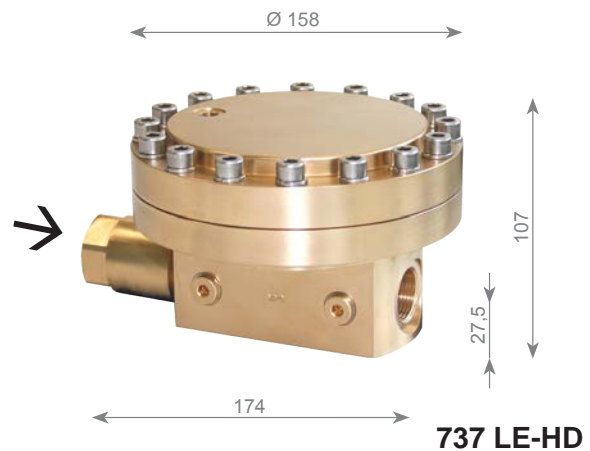

737 LE-HD



737 LE-HD-ES

	Model	
	737 LE-HD	737 LE-HD-ES
max. inlet pressure	CO ₂ O ₂ other gases	60 bar 200 bar 300 bar
Burn out test for O₂	X	
max. pilot pressure	50 bar	
outlet pressure	2 - 50 bar	
Kv-Value	1.65	
Inlet	G 3/4 F	
Filter	100 µ	
Outlet	G 3/4 F	
Pilot pressure	G 1/8 F	
Manometer	G 1/8 F	
Housing	Brass	Stainless steel (1.4404)
Cartridge	Stainless steel (1.4305)	Stainless steel (1.4404)
Membrane	CR	FPM
Spring	Stainless steel (1.4310)	Hastelloy
Weight approx.	10 kg	9.5 kg
Order-No.	278-055	278-068

DOMESTIC PRESSURE REGULATOR 737 LE-HD/S

complete solution - own medium controlled

Benefits

- complete mounted, inclusive pressure gauge, pilot pressure regulator and fittings
- anytime changeable working pressure (readjustable) – e.g. at fluctuation of temperature
- provides constant working pressure by dynamic control
- no disperse of pilot gas to the environment – closed system
- pressure gauges optionally in stainless steel and/or filled with glycerine
- indoor and outdoor installation
- additional connections (G 1/8 F) in the inlet and outlet range – e.g. pressure transmitter
- connection for wall mounting panel
- easy installation and removing

Options

- control via electrical proportional valve
- piloting by foreign gas available
- wall mounting panel
- filter

Operation / Usage

Own medium controlled pressure regulator with dome pressure regulator for mounting in pipe-works.

Function

The dome pressure regulator is used in combination with pilot pressure regulator for adjusting the required working pressure (outlet pressure).

The controlled gas (own medium) is used for the supply of pilot pressure regulator (re-controllable, closed system) by pilot gas.

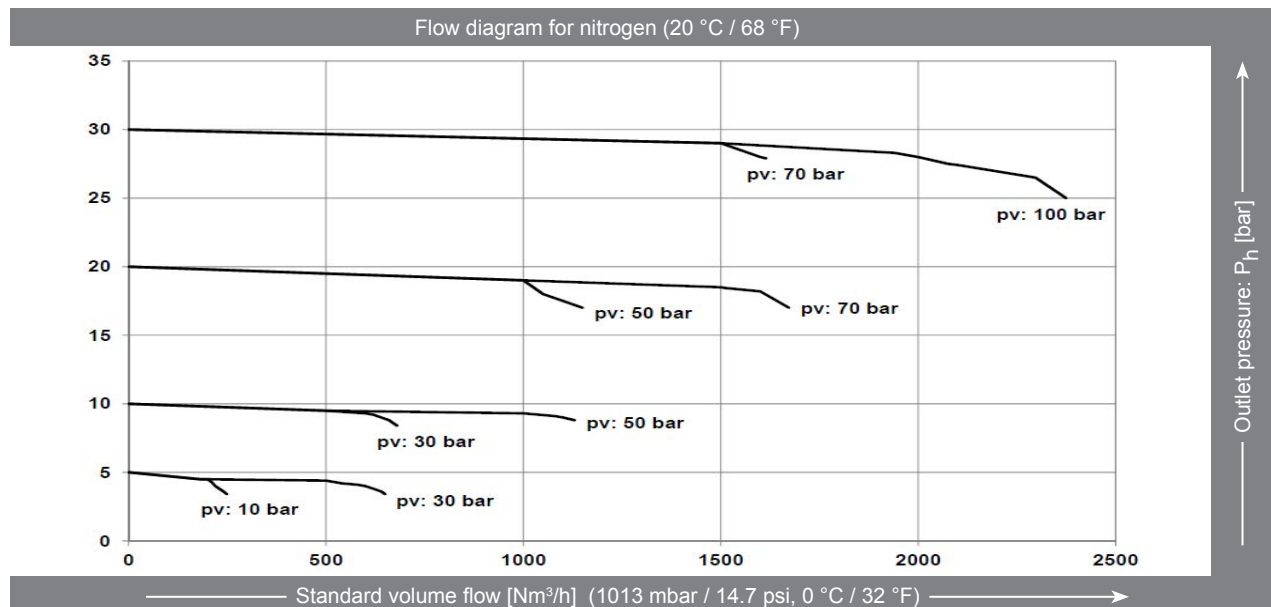
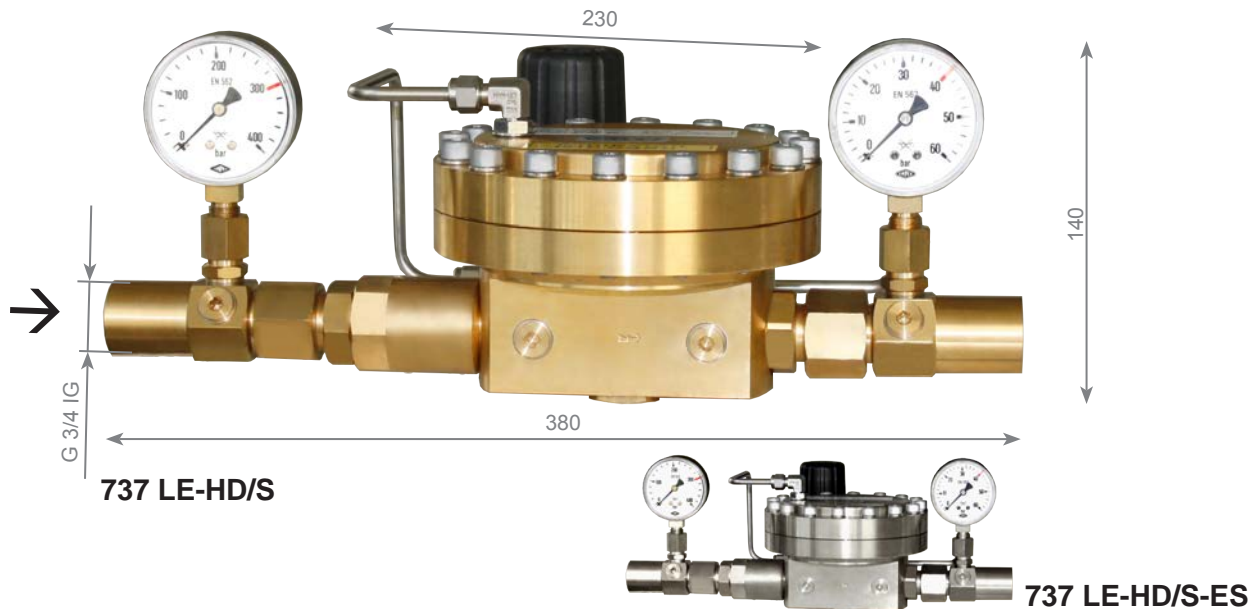

For more pressure regulator visit www.wittgas.com